

EXPOSITION TOWER ELEVATION

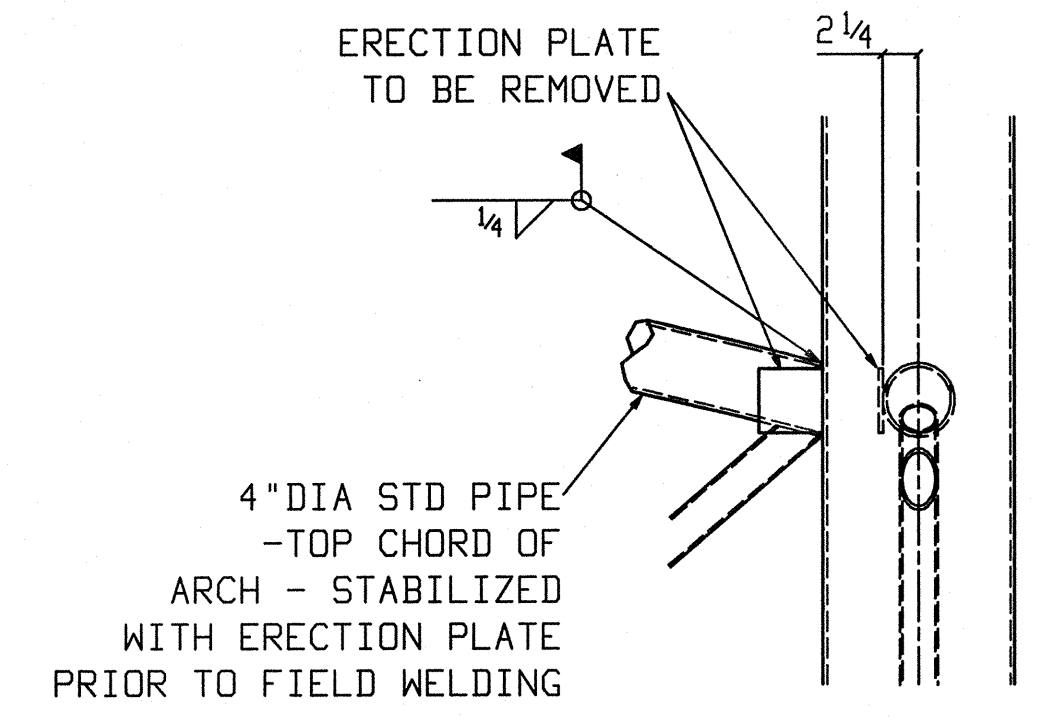

DETAIL A

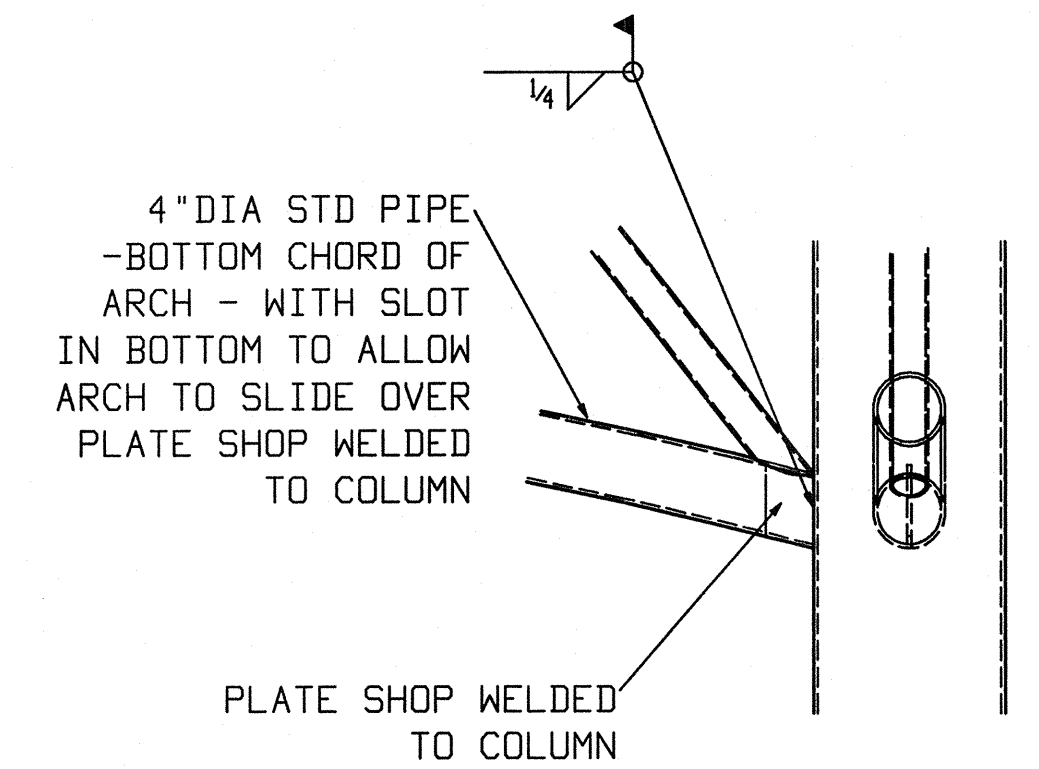

DETAIL B

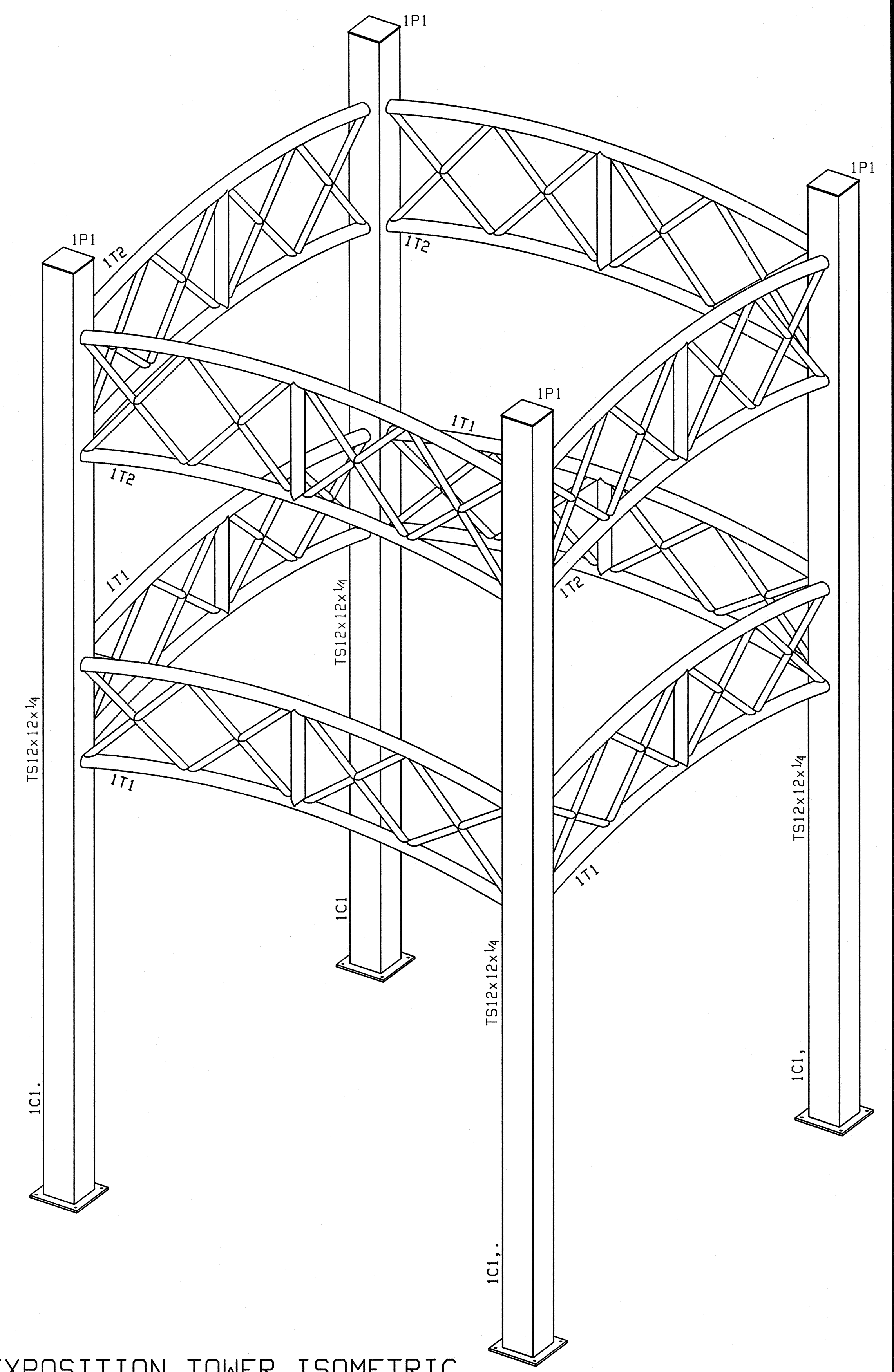

EXPOSITION TOWER ISOMETRIC

REVISIONS			ANCHOR ENTERPRISES	
			(302)629-7969	BLADES, DE
F/F	4-4-08	BAK	PROJECT	MOTORSPORTS SITE AMENITIES
APP	2-26-08	BAK		DOVER RACEWAY, DELAWARE
D	1-24-08	BAK	CUSTOMER	KENT CONSTRUCTION
PAINT			ARCH'T	SMYRNA, DELAWARE
				BECKER MORGAN GROUP
				SALISBURY, MARYLAND
HOLES		UND		
			JOB NO.	07-490
			DWG. NO.	E1 OF